

Product: MULTI N GPS

Product Order Code:
BM-02 RANGE

Compact GPS Magnetic & Self Adhesive Antenna

GPS, Galileo, QZSS

- Low profile robust amplified antenna
- RoHS 2011/65/EU & RoHS3 (2015/863/EU compliant)
- Request samples for test & evaluation via enquiry@bloomice.com



Technical Data

Dimensions	35mm x 39.6mm x 13.1mm (H) (Excluding self adhesive pad)
Weight	34g (Excluding cables and connectors)
Construction Materials	PC/ABS UL94 V0 / UV Stable
Mounting Arrangement	Magnetic & 3M Adhesive Pad Mount on any surface
Temperature Range	-40 to +85 Degree C
Protection Class	IP65

GPS, Galileo, QZSS

Frequency Range	GPS, Galileo, QZSS:	1575.42MHz +/-1.023MHz
Ceramic Patch Size		25mm x 25mm x 4mm
Impedance		50 Ohm
Polarisation		RHCP
Radiation Pattern		Hemispherical
VSWR		<1.5:1 @ 1575.42MHz
Active Gain (Amplification)		28dB @ 3v / 30dB @ 5v
Operational Voltage		2.7v to 5.5v
Current Consumption		11mA @ 2.7v / 15mA @ 5v
Power Consumption		40mW (Typical)
Axial Ratio		3dB Maximum
Noise Figure		1.5dB (Typical)
Cable types Available		LL100 50 Ohm Low Loss / RG174
Cable Length		According to customer specification
Connector		According to customer specification
Test & Measurement Conditions		300mm x 300mm x 2mm ABS / 1000mm LL100 Cable / SMA Male connector

Product: MULTI N GPS

**Product Order Code:
BM-02 RANGE**

Radiating Patterns

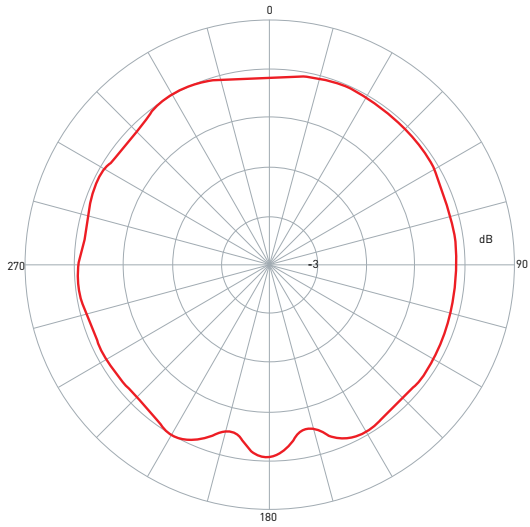

XZ Plane

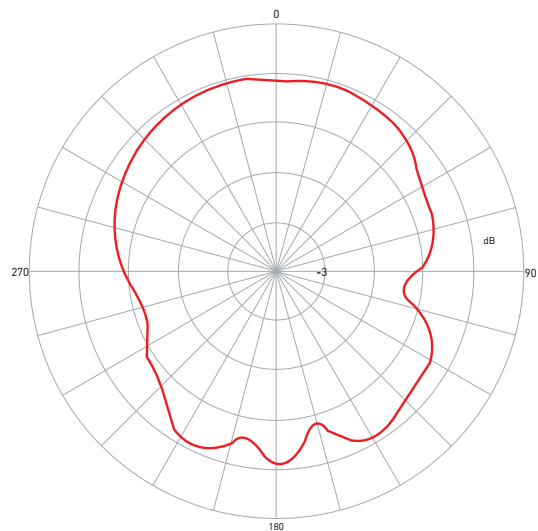

YZ Plane

CAD Data

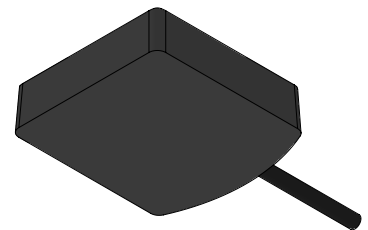
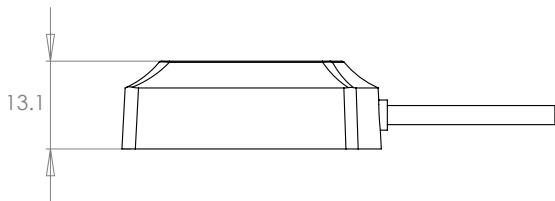
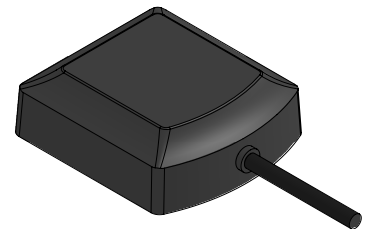
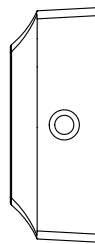
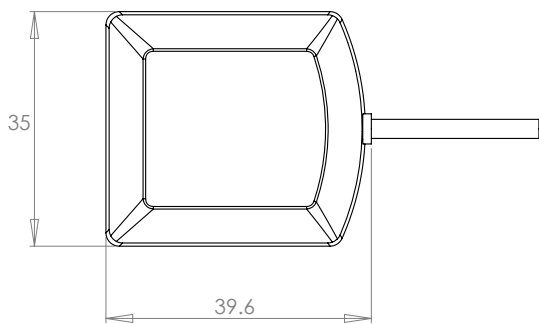

LL100 or RG174 Cable - Customised Length